



Description

They are high power downlights, available surface-mounted/suspended-mounted options, Both COB/SMD LED source options, widely for warehouses, high ceiling halls, railway stations, etc

Specification

Ref Number	GR-FM-100WR
Power	100Watt ±5%
Lumens	8500-10000lm
LED Type	COB or SMD
CCT	2700k-3000K/4000K/5700-6000K
CRI	>90
SDCM	< 3
LED driver	Built-in driver included
Control Way	ON/OFF
Input voltage	110/ 220-240VAC 50/60Hz
Efficiency	>90%
Power factor	>0.95
THD	<15%
Free flicker	Yes
Beam angle	24° for COB, SMD for 60°
Materials	Die-cast aluminum
Finished	Matt White / Black options
Insulation class	Class I
UGR	<19 anti glare
Mounting	Surface/ or Suspension mounted
IP Rating	IP20 (IP44 for front)
Dimension	Ø240*300mm
Cutout	/
Working temp	-25°C ~ +50°C
Storage temp	-30°C ~ +55°C
Standard	CE LVD EMC RoHS
Working life	>50000Hrs
Warranty	3Years/5Years

Dimension drawing

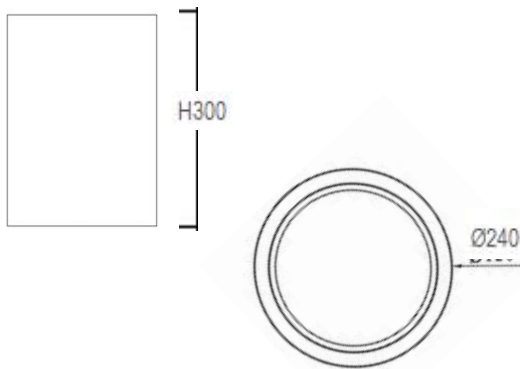

Unit: mm

Lighting Distribution

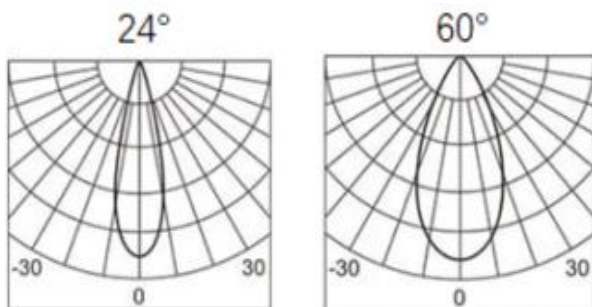

Options(Additional cost)

- DC12V/24V/36V/48V/60V input
- Matt white/Black finished options
- SDCM<2;
- Triac/0-10V/DALI dimmable options
- Suspension ropes for pendant installation

Package

QTY: CTN Size:

Gross Weight(KG):