

# 150W Low Voltage LED High Bay

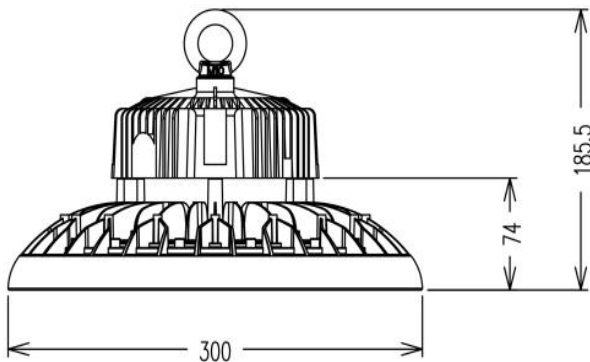

## •Dimension drawing



Unit: mm

## •Lighting Distribution

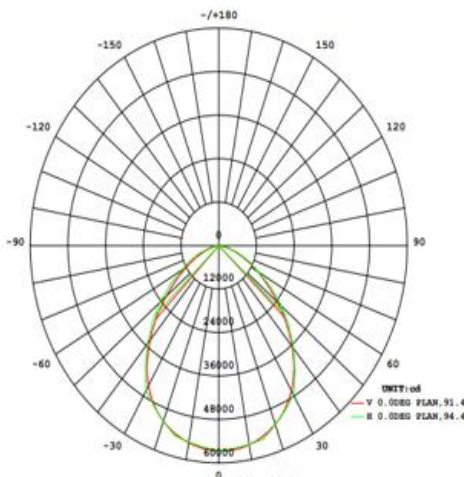

## •Description

LED high bay lights are specially designed with a low-voltage input LED driver, 24VDC input as standard, 36V, 48V, 60VDC input can be customized as well, safe low voltage, no risk of electric shock, compatible with DC power supply, and with an IP65 waterproof structure and widely used in solar warehouses, tunnels, cold storage, mines, marine cabins, energy storage stations. There are two types included- round driver and square driver type with brackets.

## •Specification

Model	GR-HB-150WB-6
Mounted	Surface/ Suspension
Power	150Watt ±5%
Dimension	Ø300*H186mm
LED Type	Lumileds SMD
Lumens	20000-22000lm
CCT	3000K/4000K/5500-6000K options
CRI	70
SDCM	<5
LED driver	External driver included
Input voltage	24VDC as standard, 36V/48V/ 60V option
Output voltage	DC36V-48VDC
Efficiency	>88%
THD	<15%
Free flicker	Yes
Materials	Die-cast aluminum+PC cover.
Finished	Black
Bracket	included / 180° rotation, metal
IK rating	IK08
IP IK Rating	IP65
Beam angle	60°/90°/120° options
Working temp	-25°C ~ +50°C
Storage temp	-30°C ~ +55°C
Standard	CE LVD EMC RoHS
Working life	>50000Hrs
Warranty	3Years
Control Way	ON/OFF

## •Options

- Radar Motion Sensor
- Triac/0-10V/DALI dimmable
- CRI80
- Warranty: 5Years
- Emergency backup (3W-5W with 1-3hrs)

## •Package

Package: 1PCS/CTNS/2.7KG  
CTN Size: 35\*35\*17CM