

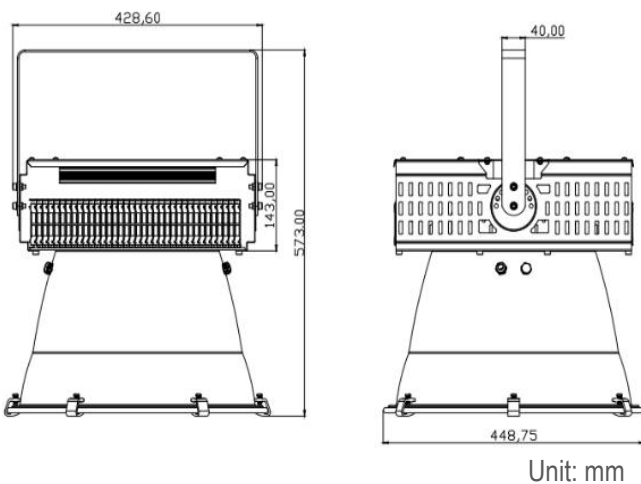

•Dimension drawing

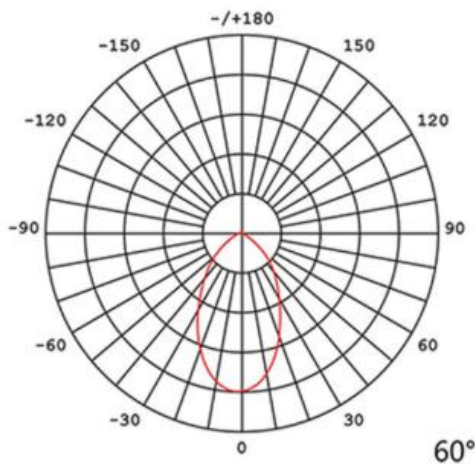

•Lighting Distribution



•Description

This LED Floodlight features a finned design for rapid heat dissipation, and is equipped with a high-strength toughed glass cover, top quality branded LED driver, making it ideal for commercial and industrial environments, such as tower cranes and construction sites.

•Specification

Model	GR-FL-800WG
Type	Industrial & Commercial
Power	800Watt ±5%
Dimension	Ø448 *H573mm
LED Typs	SMD3030
Lumens	96000-105000lm
CCT	2700-3000K/4000K/5700K-6000K
CRI	>70 or 80
SDCM	<5
LED driver	External driver included
Input voltage	100-277VAC 50/60Hz
Efficiency	>91%
Power factor	>0.95
THD	<15%
Free flicker	Yes
Materials	Die-cast aluminum+ Toughed glass.
Finished	Black
Adjustable bracket	Yes, 180° adjustable
IK rating	IK08
IP IK Rating	IP65
Beam angle	60°
Working temp	-25°C ~ +55°C
Storage temp	-30°C ~ +60°C
Standard	CE LVD EMC RoHS
Working life	>50000Hrs
Warranty	3/5Years
Control Way	ON/OFF

•Options

- DC12V/24V/36V/48V/60V input
- 0-10V/DALI dimmable
- Protection cover for LED driver
- Emergency backup (15W-35W with 1-2hrs)
- Industrial waterproof connector

•Package

Package: 1PCS/CTNS GW:12.5KG/CTNS,
CTN Size: 50*50*53CM