

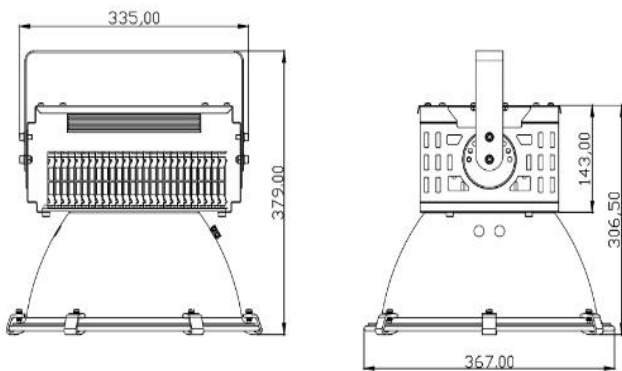

## •Dimension drawing



Unit: mm

## •Lighting Distribution

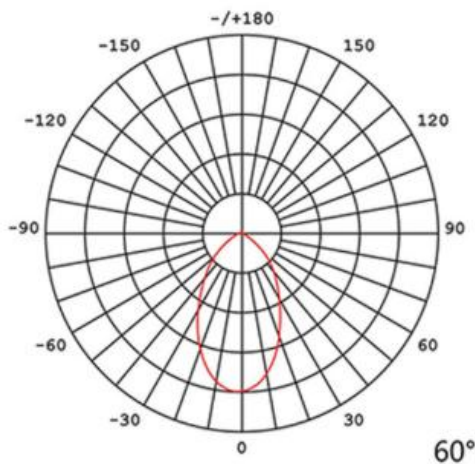

## •Description

This LED Floodlight features a finned design for rapid heat dissipation, and is equipped with a high-strength toughed glass cover, top quality branded LED driver, making it ideal for commercial and industrial environments, such as tower cranes and construction sites.

## •Specification

Model	GR-FL-300WG
Type	Industrial & Commercial
Power	300Watt ±5%
Dimension	Ø367 *H379mm
LED Typs	SMD3030
Lumens	36000-39000lm
CCT	2700-3000K/4000K/5700K-6000K
CRI	>70 or 80
SDCM	<5
LED driver	External driver included
Input voltage	120-277VAC 50/60Hz
Efficiency	>91%
Power factor	>0.95
THD	<15%
Free flicker	Yes
Materials	Die-cast aluminum+ Toughed glass.
Finished	Black
Adjustable bracket	Yes,180° adjustable
IK rating	IK08
IP IK Rating	IP65
Beam angle	25°/60°
Working temp	-25°C ~ +55°C
Storage temp	-30°C ~ +60°C
Standard	CE LVD EMC RoHS
Working life	>50000Hrs
Warranty	3/5Years
Control Way	ON/OFF

## •Options

- DC12V/24V/36V/48V/60V input
- 0-10V/DALI dimmable
- Protection cover for LED driver
- Emergency backup (15W-35W with 1-2hrs)
- Industrial waterproof connector

## •Package

Package: 1PCS/CTNS GW:6KG/CTNS,  
CTN Size: 40\*40\*43CM