



## DEEP DOWNLIGHT

Ref No: GR-DL-30WG-03



LED Downlight adopt deep anti-glare design, with top quality aluminum as housing and bridgelux chips, delivers a superior LED alternative that's up to 60% more energy efficient than the conventional downlight retrofits. It is also ideal for all commercial lighting applications. White/black/Silver reflectors optional.

### Complete Product Data

Order Number	GR-DL-30WG-03
Total Wattage	30W±5%
Mounting Type	Recessed mounted
Dimension(mm)	Ø140*H160mm
Outcut(mm)	Ø120-125mm
IP Grade	IP22
Luminaries Lumens	3000-3400lm
Beam angle	24/36°
Working temperature	-25°C ~ +55°C
Certificates standard	CE LVD EMC RoHS
Warranty	3/5Years
Package	/

### Control Gear/Driver Data

LED driver brand	<b>LiFud</b> <b>EAGLERISE</b> <b>OSRAM</b>
Input voltage	220-240VAC 50/60Hz
Output voltage	30-42Vdc
Output current	750-800mA
Power Factor	>0.9
Surge protection	1-2KV
Efficiency	>88% @230V
IP Grade	IP20
THD	<10% @230V
Dimmable	No, but available to select it as Triac/0-10V/DALI if needed
Free flicker	Yes
Protection	Open Circuit Protection / short Circuit protection/
Certificates	CCC、RCM、CE、CB
Warranty	3/5Years

## Material&Housing Data

Housing Color	White finished
Housing Material	Aluminum
Lens	High quality PC lens
Reflector material	PC reflector, white as standard, black/silver optional
Fixation material	Steel
Connector	Quickly connectors

## Photometric Data

LED chip brand	Bridgelux
Chip type	COB
Color temperature	2700-2800K/3000-3200K/4000-4500K/ 5700-6000K/ 6000-6500K
CRI	>Ra90
Life time	>50000Hrs
Lumens	110-130lm/W
SDCM	<5
Lumens maintenance	99.9%@1000hrs/ 99%@3000hrs /98%@10000hrs. (LM80)

## Optional

Dimming Type	Triac dim/ 0-10V dim/ DALI dimmable optional
Dimming driver brand	<b>KOPU</b> <b>EAGLERISE</b> <b>OSRAM</b> <b>EUCHIPS</b> <b>Lifud</b>
Emergency backup	Battery backup with 1-3Hours for 3-5Watt

## Dimension

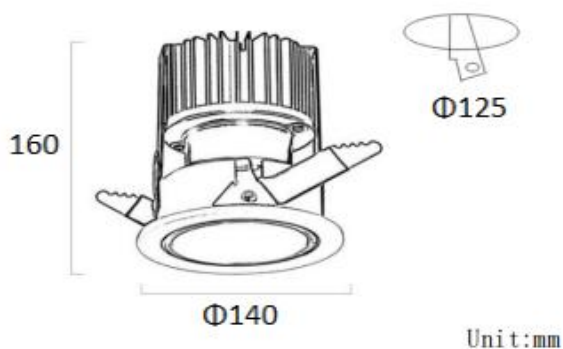

## Lighting Distribution

