



DEEP RECESSED DOWNLIGHT

Ref No: GR-DL-15WG-4



LED Downlight adopt deep anti-glare design, it is ok to be rotation 30°, and consists of Osram/Bridgelux chips, delivers a superior LED alternative that's up to 60% more energy efficient than the conventional downlight retrofits. It is also ideal for all commercial lighting applications.

Complete Product Data

Order Number	GR-DL-15WG-4
Total Wattage	15W±5%
Mounting Type	Recessed mounted
Dimension(mm)	Ø105*H103mm
Outcut(mm)	Ø90-95mm
IP Grade	IP20 for complete product (IP44 from front)
Luminaries Lumens	1350-1600lm
Beam angle	24° as standard, 15/36/60° optional
Working temperature	-25°C ~ +55°C
Certificates standard	CE LVD EMC RoHS
Warranty	3/5Years
Package	/

Control Gear/Driver Data

LED driver brand	LiFud EAGLERISE OSRAM
Input voltage	110/220-240VAC 50/60Hz
Output voltage	30-42Vdc
Output current	350mA
Power Factor	>0.5 as standard; >0.9 optional
Surge protection	1KV
Efficiency	>87% @230V
IP Grade	IP20 (From front, it is up to IP44)
THD	<15% @230V
Dimmable	No, but available to select it as Triac/0-10V/DALI if needed
Free flicker	Yes
Protection	Open Circuit Protection / short Circuit protection/
Certificates	CCC、RCM、CE、CB
Warranty	3/5Years

Material&Housing Data

Housing Color	White finished as standard, black optional
Housing Material	Aluminum
Cover	PMMA or glass cover
Reflector material	/
Fixation material	Steel
Connector	Quickly connectors

Photometric Data

LED chip brand	Bridgelux / Epistar
Chip type	COB
Color temperature	2700-2800K/3000-3200K/4000-4500K/ 5700-6000K/ 6000-6500K
CRI	>Ra90
Life time	>50000Hrs
Lumens	110-130lm/W
SDCM	<5
Lumens maintenance	99.9%@1000hrs/ 99%@3000hrs /98%@10000hrs. (LM80)

Optional

Dimming Type	Triac dim/ 0-10V dim/ DALI dimmable optional
Dimming driver brand	KOPU EAGLERISE OSRAM EUCHIPS Lifud
Emergency backup	Battery backup with 3Hours for 2-3Watt

Dimension & Install

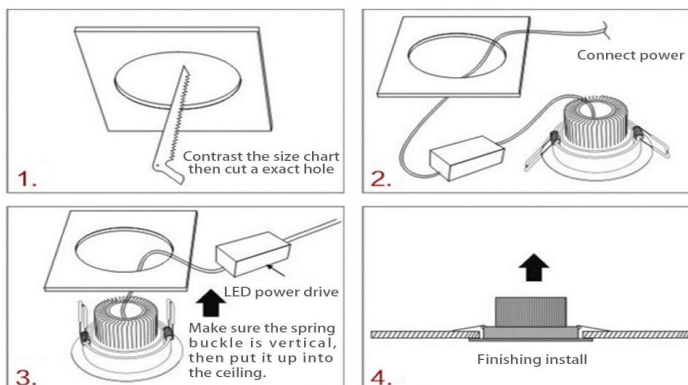
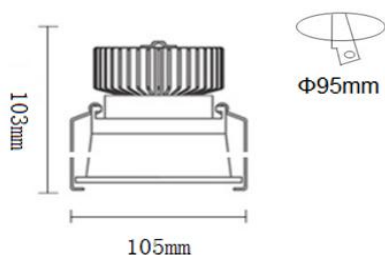

Lighting Distribution

