

GR-HB-250WM LED High Bay Lights

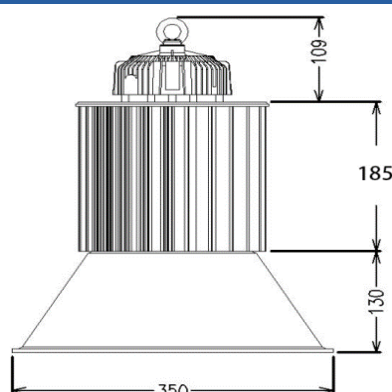

Dimension



Unit:mm

Description&Feature

LED high bay light with copper heat sink, delivers a superior LED alternative that's up to 60% more energy efficient than the conventional HPS, Metal halide bay light retrofits.

It is also ideal for all industrial lighting applications as well as public indoor spaces, such as warehouses, bus stations, Mine, Factories, etc.

Its lifetime can be up to 10 years. The other extra function such as dimming/ motion sensor also can be available.

Cover options

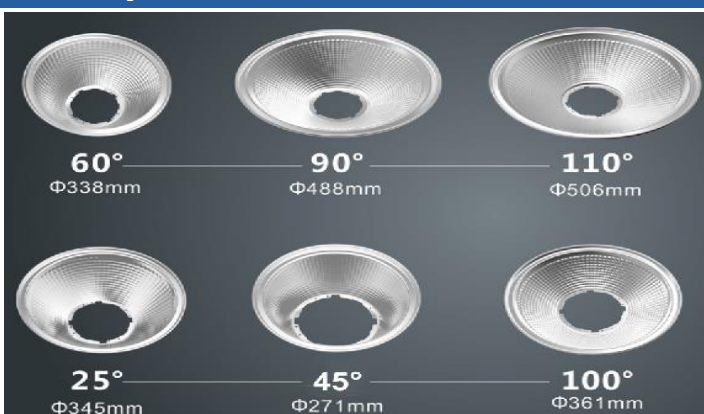

Specification

Model	GR-HB-250WM
Dimension(mm)	D350*H424mm
Outcut	/
Power	250W±5%
LED Chips brand	Philips/Osram/Bridgelux SMD3030 252PCS
Lumens	25000-28000lm
Color temperature	3000K/4000K-4500K/6000K-6500K
Driver	Isolated driver/Meanwell/Philips/DONE Brand driver
Input voltage	100-240VAC / 220-240VAC 50/60Hz
Power factor	>0.95
CRI	>80
SDCM	<5
Working life	>50000Hrs
Efficiency	>89%
Materials	Die-cast aluminum+Aluminum cover, Black/Silver finished options
Beam angle	25/45/60/90/120° options
THD	<15%
IP Grade	IP65 waterproof
Dimmable	No. but it is ok to do Triac/0-10V/DALI Dimming if needed
Working temperature	-30°C~+55°C
Package	25*25*43CM/PCS/CTNS
Standard	CE LVD EMC RoHs
Warranty	2/3/5Years options